

System No. C-AJ-8233 XHEZ.C-AJ-8233 Through-penetration Firestop Systems

Page Bottom

Design/System/Construction/Assembly Usage Disclaimer

- Authorities Having Jurisdiction should be consulted in all cases as to the particular requirements covering the installation and use of UL Certified products, equipment, system, devices, and materials.
- Authorities Having Jurisdiction should be consulted before construction.
- Fire resistance assemblies and products are developed by the design submitter and have been investigated by UL for compliance with applicable requirements. The published information cannot always address every construction nuance encountered in the field.
- When field issues arise, it is recommended the first contact for assistance be the technical service staff provided by the product manufacturer noted for the design. Users of fire resistance assemblies are advised to consult the general Guide Information for each product category and each group of assemblies. The Guide Information includes specifics concerning alternate materials and alternate methods of construction.
- Only products which bear UL's Mark are considered Certified.

XHEZ - Through-penetration Firestop Systems

XHEZ7 - Through-penetration Firestop Systems Certified for Canada

[See General Information for Through-penetration Firestop Systems](#)

[See General Information for Through-penetration Firestop Systems Certified for Canada](#)

System No. C-AJ-8233

December 01, 2015

ANSI/UL1479 (ASTM E814)	CAN/ULC S115
F Rating — 2 Hr	F Rating — 2 Hr
T Rating — 1/4, 1-1/4 and 1-3/4 Hr (See Items 2, 3 and 4)	FT Rating — 1/4, 1-1/4 and 1-3/4 Hr (See Items 2, 3 and 4)
	FH Rating — 2 Hr
	FTH Rating — 1/4, 1-1/4 and 1-3/4 Hr (See Items 2, 3 and 4)

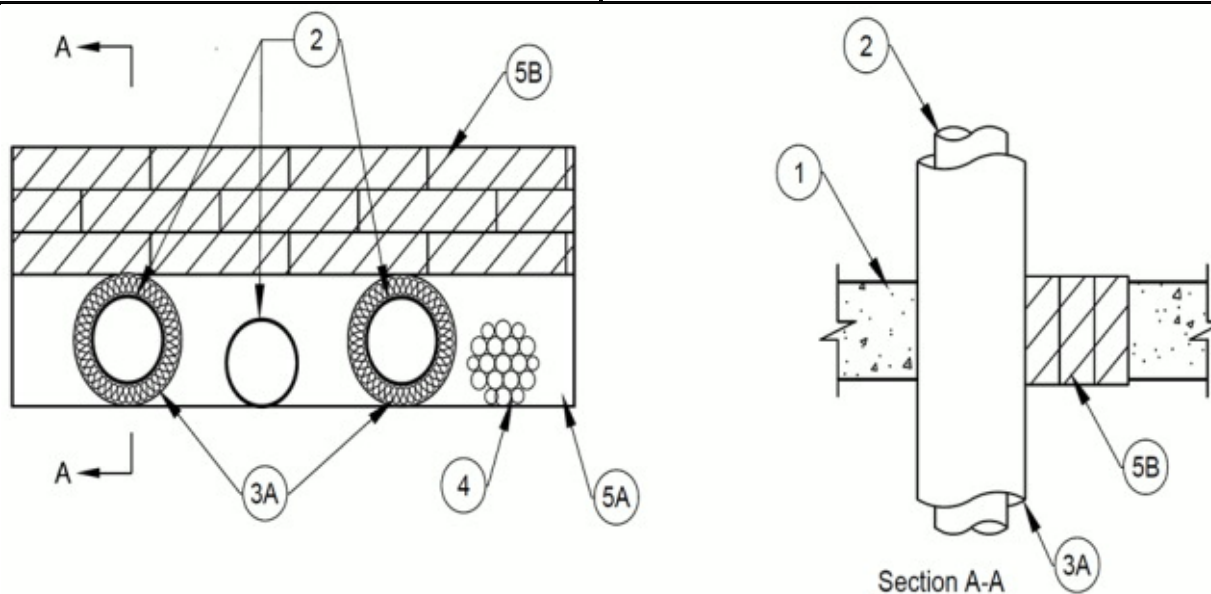

1. Floor or Wall Assembly — Min 4-1/2 in. (114 mm) thick reinforced lightweight or normal weight (100-150 pcf or 1600-2400 kg/m³) concrete. Wall may also be constructed of any UL Classified **Concrete Blocks***. Max area of opening is 384 in.² (2477 cm²) with a max dimension of 32 in. (813 mm).

See **Concrete Blocks** (CAZT) in the Fire Resistance Directory for names of manufacturers.

2. Through-Penetrant — One or more pipes or tubes to be installed within the opening. The total number of through-penetrants is dependent on the size of the opening and types and sizes of the penetrants. Any combination of the penetrants described below may be used provided that the following parameters relative to the spacing between the pipes are maintained. The separation between cable bundle, tubes and insulated tubes shall be a min 1 in. (25 mm). Pipes or tubes to be rigidly supported on both sides of floor or wall assembly. The following types and sizes of metallic

pipes or tubes may be used:

- A. **Copper Tubing** — Nom 4 in. (102 mm) diam (or smaller) Type L (or heavier) copper tube.
- B. **Copper Pipe** — Nom 4 in. (102 mm) diam (or smaller) Regular (or heavier) copper pipe.
- C. **Steel Pipe** — Nom 4 in. (102 mm) diam (or smaller) Schedule 5 (or heavier) steel pipe.
- D. **Iron Pipe** — Nom 4 in. (102 mm) diam (or smaller) cast or ductile pipe.
- E. **Iron Pipe** — Nom 4 in. (102 mm) diam (or smaller) electric metallic tubing (EMT) or steel conduit.

The hourly T, FT and FTH Ratings shall not exceed 1/4 hr when metallic pipe or tubing is used with no pipe insulation.

3. **Pipe Insulation** — (Optional) — The following types of pipe insulation may be used:

- A. **Pipe Covering*** — Nom 1 in. (25 mm) or thinner thick hollow cylindrical heavy density (min 3.5 pcf) glass fiber units jacketed on the outside with an all service jacket. Longitudinal joints sealed with metal fasteners or factory-applied self-sealing lap tape. Transverse joints secured with metal fasteners or with butt tape supplied with the product. **The hourly T, FT and FTH Ratings shall not exceed 1-3/4 hr when metallic pipe or tubing is used with this pipe covering.**

See **Pipe and Equipment Covering — Materials** (BRGU) category in the Building Materials Directory for names of manufacturers. Any pipe covering material meeting the above specifications and bearing the UL Classification Marking with a Flame Spread Index of 25 or less and a Smoke Developed Index of 50 or less may be used.

4. **Cables** — Max 4 in. (102 mm) diam tight bundle of cables installed within the opening and rigidly supported on both sides of floor or wall assembly. Cable bundle may be any combination of the following types and sizes of cables:

- A. Max 1/C 750 kcmil (or smaller) single copper conductor power cable with thermoplastic insulation and polyvinyl chloride (PVC) jacket.
- B. Max 300 pair No. 24 AWG (or smaller) copper conductor telecommunication cables with PVC insulation and jacket material.
- C. Max 7/C copper conductor No. 12 AWG multiconductor power and control cables with PVC or cross-linkewd polyethylene (XLPE) insulation and PVC jacket.
- D. Multiple fiber optical communication cables jacketed with PVC and having a max outside diam of 1/2 in. (13 mm).
- E. Max 3/C copper conductor No. 10 AWG (or smaller) with bare aluminum ground, PVC insulated steel or aluminum **Metal-Clad** cable.
- F. Max No. 18 AWG Type RG/6 coaxial cable with polyvinyl chloride insulation.

The hourly T, FT and FTH Ratings shall not exceed 1-1/4 hr when cables are used.

5. **Firestop System** — The firestop system shall consist of the following:

- A. **Fill, Void or Cavity Material*** — Min 4-1/2 in. (114 mm) thickness of fill material applied between cables and pipes, and around the periphery of the cables/pipes. Max area of fill is 224 in² (1445 cm²) with a maximum dimension of 32 in (813 mm). The max vertical annular space to the periphery of the opening or block / foam interface shall be 3-1/2 in (89 mm) and horizontal respectively 8 in. (203 mm). After installation of blocks (Item 5B), fill material to be forced between blocks and periphery of opening to max extent possible from top surface of floor or both surfaces of wall assembly.

ZAPP-ZIMMERMANN GMBH — Fire Protection Foam ZZ 360

- B. **Fill, Void or Cavity Material** — Blocks tightly-packed to fill annular space between penetrants or foam and periphery of opening installed with 5 in. (127 mm) dimension projecting through floor or wall and centered within the opening.

ZAPP-ZIMMERMANN GMBH — Fire Protection Block ZZ 260

*** Indicates such products shall bear the UL or cUL Certification Mark for jurisdictions employing the UL or cUL Certification (such as Canada), respectively.**

Last Updated on 2015-12-01

[Questions?](#)

[Print this page](#)

[Terms of Use](#)

[Page Top](#)

© 2015 UL LLC

The appearance of a company's name or product in this database does not in itself assure that products so identified have been manufactured under UL's Follow-Up Service. Only those products bearing the UL Mark should be considered to be Certified and covered under UL's Follow-Up Service. Always look for the Mark on the product.

UL permits the reproduction of the material contained in the Online Certification Directory subject to the following conditions: 1. The Guide Information, Assemblies, Constructions, Designs, Systems, and/or Certifications (files) must be presented in their entirety and in a non-misleading manner, without any manipulation of the data (or drawings). 2. The statement "Reprinted from the Online Certifications Directory with permission from UL" must appear adjacent to the extracted material. In addition, the reprinted material must include a copyright notice in the following format: "© 2015 UL LLC".